

INVESTIGATION OF THE CHARACTERISTICS OF
HEAT-TRANSMITTING ELEMENTS WITH SHORT
FINNED RIBS

A. F. Savostin and A. M. Tikhonov

UDC 536.244

Results are presented of an experimental investigation of the heat exchange and hydraulic resistance of heat-transmitting elements with short finned ribs. The influence of the relative fin length and their mutual disposition on the characteristics is examined. Heat-transmitting elements are compared for size and weight indices in the investigated range of numbers $Re = 200-4000$ for the case of their application in gas-turbine engine regenerators.

The use of short finned ribs is one of the simplest and most accessible methods of intensifying the heat exchange in compact heat-transmitting elements. The characteristics of such separate heating surfaces are presented in [1]. However, the investigations conducted there are not systematic in nature (the choice of the geometric size of the samples is determined accidentally in many cases) and it is difficult to compose a clear representation of the influence of the fundamental geometric parameters, such as the relative fin length and their mutual disposition, on the heat exchange and hydraulic resistance by means of their results.

Results of an experimental investigation of the characteristics of several kinds of heating surfaces with short finned ribs are presented below. Attempts to clarify the influence of the separate geometric parameters in as pure a form as possible have been made: the test samples were fabricated in small batches with identical geometric dimensions (except those under test).

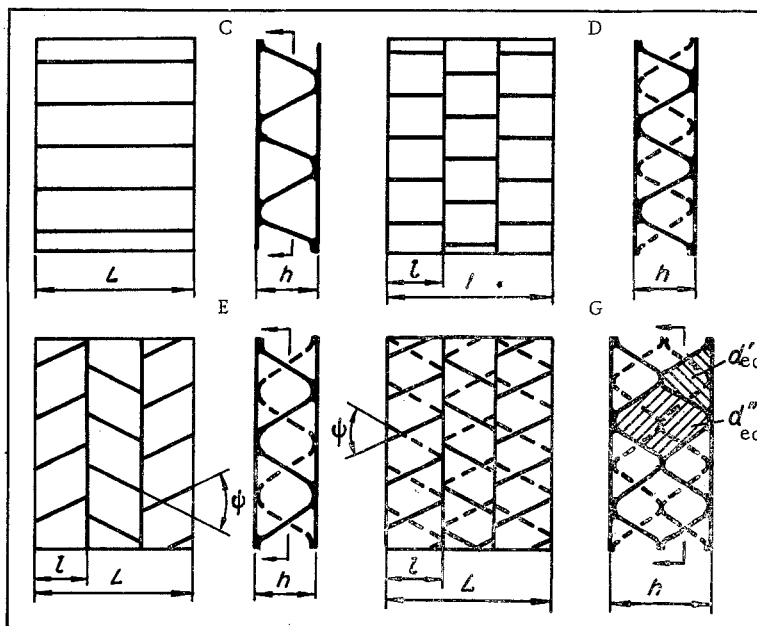

Fig. 1. Kinds of heating surfaces investigated.

P. I. Baranov Central Institute of Aviation Motor Construction, Moscow. Translated from *Inzhenerno-Fizicheskii Zhurnal*, Vol. 21, No. 4, pp. 713-721, October, 1971. Original article submitted June 24, 1970.

© 1974 Consultants Bureau, a division of Plenum Publishing Corporation, 227 West 17th Street, New York, N. Y. 10011. No part of this publication may be reproduced, stored in a retrieval system, or transmitted, in any form or by any means, electronic, mechanical, photocopying, microfilming, recording or otherwise, without written permission of the publisher. A copy of this article is available from the publisher for \$15.00.

TABLE 1. Geometric Dimensions of the Test Specimens

Surface	ψ, rad	d_{eq}, mm	L/d_{eq}	L'/d_{eq}	$\frac{d''_{\text{eq}}}{d_{\text{eq}}}$	h, mm	h_c, mm	t, mm	l_c, mm	$\delta_{\text{pl}}, \text{mm}$	$\delta_{\text{pr}}, \text{mm}$	δ_1, mm	r_1, mm	r_2, mm	r_3, mm
C-1	—	1,19	52,1	52,1	—	1,46	1,54	2,53	4,1	0,15	0,07	0,098	0,28	0,28	0,10
C-2	—	1,06	64,2	64,2	—	1,58	1,6	2,54	4,22	0,2	0,02	0,12	0,5	0,5	0,03
D-1	—	1,06	62,3	15,6	—	"	"	"	"	"	"	"	"	"	"
D-2	—	"	"	7,74	—	"	"	"	"	"	"	"	"	"	"
D-3	—	"	"	3,87	—	"	"	"	"	"	"	"	"	"	"
D-4	—	"	"	1,89	—	"	"	"	"	"	"	"	"	"	"
E-1	0,349	1,25	49,6	12,4	—	1,46	1,54	2,53	4,1	0,15	0,07	0,098	0,28	0,28	0,10
E-2	0,175	1,21	51,2	12,8	—	1,46	1,54	"	4,1	"	"	"	"	"	"
E-3	0,175	1,21	51,2	6,3	—	1,47	1,55	"	4,12	"	"	"	"	"	"
E-4	0,175	1,24	50,0	3,0	—	1,47	1,55	"	4,12	"	"	"	"	"	"
G-1	0,349	1,46	42,3	10,6	1,43	2,98	1,54	"	4,1	"	"	"	"	"	"
G-2	0,175	1,45	42,7	10,7	1,43	2,98	1,54	"	4,1	"	"	"	"	"	"
G-3	0,175	1,39	44,6	11,1	1,10	2,99	1,58	"	4,3	"	"	"	0,56	"	0,10

Small heat exchanges with crossing motion of the working media (air–water) were fabricated for the test specimens. The heat exchangers consist of welded flat and corrugated plates of 1Kh18N9T steel. Heating surfaces with four kinds of channels (Fig. 1) were used in the air cavity of the heat exchangers.

Surfaces of the type C with smooth continuous walls were intended for use in obtaining the initial characteristics. The surfaces C-1 and C-2 (Table 1) were distinguished by the shape of the channel cross section, which is associated with the differences in the technology of their fabrication.

To fabricate the surface C-1 (as well as surfaces of the type E and G), pure G70NKhA sheet solder, 0.07 mm thick, which filled and rounded off sharp corners at sites connecting the flat and corrugated plates (the radius r_3 in Fig. 2), was used. The resulting diminution in surface area of the flat and corrugated plates was 16–18% in elements of type C-1 and E, and 10–11% in elements of type G.

Copper solder, deposited galvanically and in a 0.02 mm thickness on the flat plate, was used to fabricate the C-2 surface (as well as surfaces of the type D). After soldering, the diminution in the area of the flat and corrugated plate surfaces of these elements was 3%, and the channels had approximately semicircular cross sections with two acute angles.

The finning in surfaces of the type D (Fig. 1) was produced from narrow corrugated tapes shifted half a space relative to each other. Surfaces of the type E had finning from tapes with an oblique disposition of the corrugations. Surfaces of the type G had double-deck finning from corrugated tapes with corrugations disposed at the angle ψ relative to each other.

Channels of the type C (Fig. 1) were used for the cooling fluid duct in all the test specimens.

The corrugated plates were obtained by rolling steel tapes between pinions (modulus 0.8 mm) with an evolute (the surfaces C-2 and D) or triangular tooth profile (the surfaces C-1, E, G-1, and G-2). One pinion with an evolute and the other with a triangular tooth profile were used to corrugate tapes for the surface G-3.

The geometric dimensions of the test specimens are presented in Table 1 and the fundamental notation of the geometric dimensions is shown in Figs. 1 and 2.

The experimental apparatus is shown in Fig. 3. The thermal characteristics were taken off at a practically constant channel wall temperature, ensured by intensive pumping of the cooling fluid at the temperature $T_{f1} \approx T_{f2} = 278\text{--}288^\circ\text{K}$ through the heat exchanger. The tests were conducted for two values of the air temperature at the entrance: $T_{\text{air}1} = 368^\circ\text{K}$ and 463°K .

The hydraulic characteristics were determined for an isothermal air flow, i. e., without preliminary heating of the air or delivery of cooling fluid.

The Re number in the channels was changed by regulating the air discharge at an approximately identical pressure of 10.5–13.0 N/m².

The air and water temperatures $T_{\text{air}1}$, $T_{\text{air}2}$, T_{f1} , and T_{f2} were measured by mercury thermometers with a 0.1°K scale division, $p_{\text{air}1}$ by a mercury piezometer, the pressure drop Δp_{air} by a water piezometer or inclined micromanometer, the air discharge G_{air} by a calibrated measuring diaphragm.

The physical parameters of the air were determined by means of the mean values of the temperature and pressure $p_{\text{air}} = p_{\text{air}1} - 0.5\Delta p_{\text{air}}$, $T_{\text{air}} = 0.5(T_{f1} + T_{f2}) + \Delta T_{\text{log}}$.

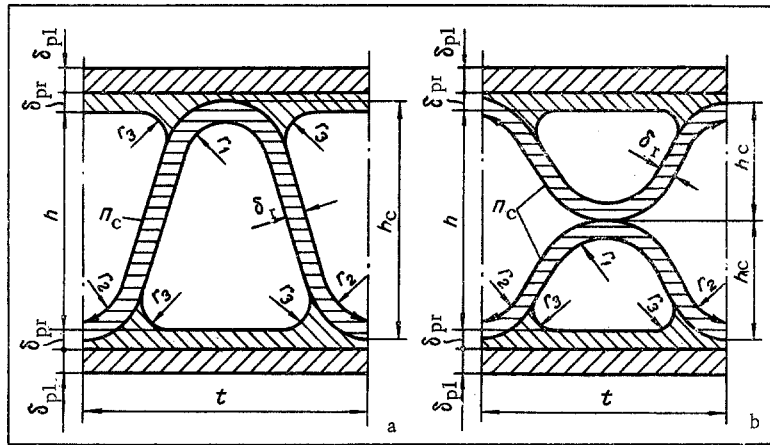

Fig. 2. Channel cross sections (corrugations shown provisionally in a normal section): a) heating surfaces of types C, D, and E; b) of type G.

In all cases the velocity W in the channels was calculated under the assumption that the air moves parallel to the heat-exchanger axis. The area of the through section is hence $S_{\text{air}} = V_{\text{air}}/L$. The equivalent channel diameter is

$$d_{\text{eq}} = 4V / F_{\text{air}}$$

The coefficient of heat exchange (first approximation) was calculated by means of the formula

$$\alpha'_{\text{air}} = \frac{k}{1 - kF_{\text{air}}/\alpha_f F_f}$$

where $k = c_r G_{\text{air}}(T_{\text{air}1} - T_{\text{air}2})/F_{\text{air}}\Delta T_{\text{log}}$.

The quantity α_f was determined by empirical dependences. In the tests conducted the ratio was $\alpha_f F_f / kF_{\text{air}} = 40-100$; hence a 20-30% error in estimating α_f could result in only a 0.2-0.3% error in determining α'_{air} .

The value found for α'_{air} was used to estimate the coefficient of thermal resistance of the ribs ψ_r , which was taken into account in the determination of the final value of α_{air} :

$$\alpha_{\text{air}} = \frac{\alpha'_{\text{air}}}{1 - \frac{F_r}{F_{\text{air}}} (1 - \psi_r)}$$

The coefficient of hydraulic resistance in an isothermal air flow is

$$\xi = \left[\frac{\Delta p_{\text{air}}}{\gamma W^2 / 2g} - (K_c + 1 - \sigma^2) \right] \frac{d_{\text{eq}}}{L}$$

As special tests conducted with the pressure receivers at diverse distances from the heat exchanger endface showed, the measured pressure $p_{\text{air}2}$ practically equals the static pressure at the exit from the channels. Hence, in calculating ξ the term $(1 - \sigma^2 - K_e)$, which takes account of pressure recovery at the exit, was assumed to be zero.

An analysis of the errors showed that the errors in determining the fundamental quantities do not exceed $\delta Re = \pm 2.5\%$, $\delta Nu = \pm 5-6\%$, $\delta \xi = \pm 5-7\%$.

The validity of the method of investigation used and the satisfactory accuracy of the data obtained were verified by control tests with a tubular heat exchanger ($d_{\text{eq}} = 2.5$ mm, $L/d_{\text{eq}} = 99$), the results of which corresponded well with the standard dependences.

The test results are presented in Table 2.

For small values of the numbers $Re < 600$ the characteristics of the surface C-1 were similar to the theoretical dependences $Nu_{\infty} = 2.7$ and $\xi = 53/Re$ for stabilized laminar flow in triangular channels (Table 2). The transition to turbulent flow occurs smoothly without any definite transition point and for essentially

TABLE 2. Results of Testing the Specimens

Re	C-1		C-2		D-1		D-2		D-3		D-4		E-1	
	Nu	ξ	Nu	ξ	Nu	ξ	Nu	ξ	Nu	ξ	Nu	ξ	Nu	ξ
200	2,7	0,265	1,95	0,240	2,1	0,260	2,3	0,275	2,75	0,300	2,95	0,335	—	0,355
300	2,94	0,177	2,05	0,170	2,25	0,180	2,65	0,195	3,2	0,220	3,45	0,260	4,65	0,274
400	3,15	0,137	2,15	0,135	2,45	0,145	2,95	0,160	3,7	0,180	3,95	0,210	5,25	0,230
600	3,5	0,094	2,45	0,095	2,9	0,105	3,60	0,115	4,55	0,135	4,85	0,160	6,2	0,182
1000	4,3	0,068	3,5	0,064	4,2	0,073	5,0	0,083	6,5	0,097	7,1	0,120	7,8	0,148
2000	7,1	0,05	6,1	0,042	7,25	0,050	8,8	0,057	11,0	0,069	12,4	0,089	11,5	0,116
4000	12,2	0,035	—	—	—	—	—	—	—	—	—	—	16,6	0,088

Re	E-2		E-3		E-4		G-1		G-2		G-3	
	Nu	ξ	Nu	ξ	Nu	ξ	Nu	ξ	Nu	ξ	Nu	ξ
200	—	0,300	—	0,345	—	0,375	—	0,45	—	0,385	—	0,33
300	3,88	0,222	4,65	0,263	—	0,295	4,9	0,34	4,75	0,292	4,3	0,250
400	4,4	0,182	5,25	0,216	5,75	0,250	5,5	0,287	5,15	0,242	4,7	0,205
600	5,3	0,136	6,2	0,165	7,2	0,197	6,4	0,220	5,90	0,185	5,5	0,155
1000	6,75	0,103	7,8	0,128	9,5	0,167	8,2	0,182	7,5	0,148	6,9	0,120
2000	9,8	0,075	11,5	0,098	14,2	0,137	11,4	0,142	10,5	0,113	9,8	0,094
4000	14,8	0,054	16,6	0,075	20,5	0,110	16,1	0,108	14,8	0,083	14,0	0,071

lower values of the criterion Re than for circular channels. Such a flow is characteristic for surfaces with channels of limited length and complex cross-sectional shape [1].

The quantity Nu turned out to be somewhat lower in channels of type C-2 than in channels of type C-1 (Table 2). The ribs in the surface C-2 form a sharp wedge with the separating plate in the zone of which the surface has reduced heat exchange [2]. If this wedge is filled in with solder (as in the channels C-1), the heat exchange does not change in practice, and the area enclosed within the heating surface is diminished.

Intensification of the heat exchange in surfaces of type D is achieved by periodic restoration of the boundary layer on the short ribs. As the width of the corrugated tapes diminishes, the heat exchange and hydraulic losses in such elements grow.

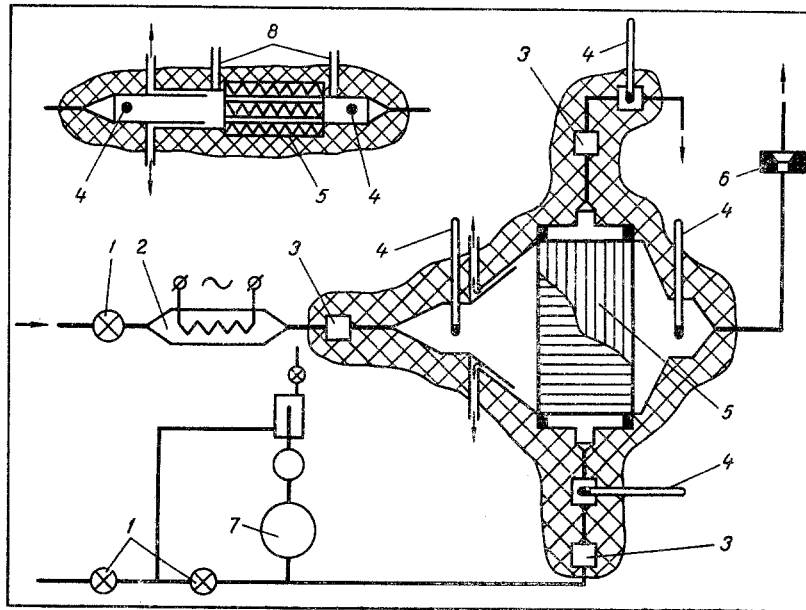

Fig. 3. Diagram of the experimental apparatus: 1) tap; 2) air heater; 3) mixer; 4) mercury thermometer; 5) test specimen; 6) measuring diaphragm; 7) rod gauge; 8) pressure receiver.

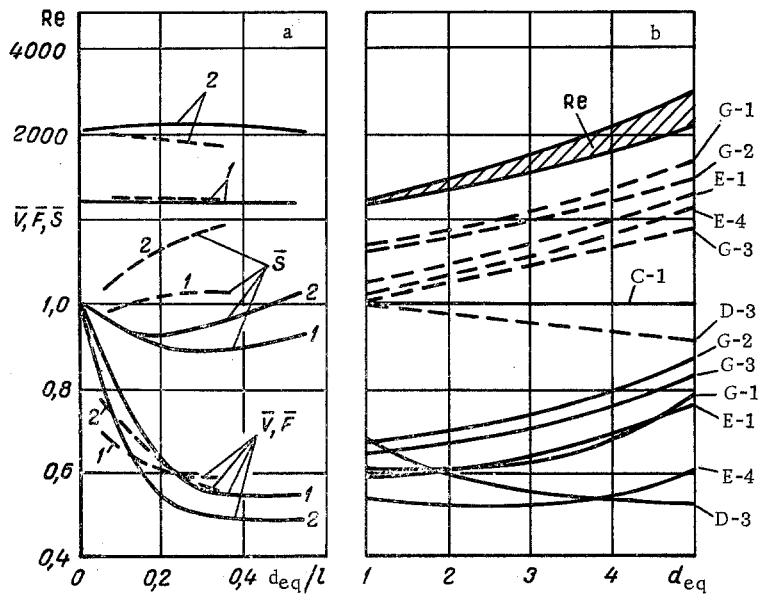

Fig. 4. Change in the size-weight indices of a heat exchanger using diverse kinds of heating surfaces (countercurrent $\eta_r = 0.8$, $\sum (\Delta p/p) = 5\%$, $G_I = G_{II}$, $\delta/d_{eq} = 0.1$, $T_I = 720^\circ\text{K}$, $T_{II} = 650^\circ\text{K}$, $p_I = 10.8 \text{ N/m}^2$, $p_{II} = 59 \text{ N/m}^2$): a: 1) $d_{eq} = 1 \text{ mm}$; 2) 4; solid lines are surfaces of type D (indices of the surface C-2 are taken as the initial indices); dashes are surfaces of type E (indices of the surface C-1 are taken as the initial indices); b) solid lines are \bar{V} , \bar{F} and dashes are \bar{S} (indices of the surface C-1 are taken as the initial indices), d_{eq} , mm.

The change in the quantity Nu occurs especially intensively as l/d_{eq} diminishes to 4 (Table 2). For the surface D-3 ($l/d_{eq} = 3.87$) the values of Nu are 1.7-1.8-fold greater than for the surface C-2 ($l/d_{eq} = 64.2$). Attention is turned to the advantageous relationship between the heat exchange and hydraulic resistance coefficients, which increase approximately proportionately. As the tape width diminishes further to $l/d_{eq} = 1.89$ (the surface D-4), the growth of the heat exchange is retarded, but the hydraulic resistance continues to increase sufficiently intensively.

The results of testing specimens of type D (see Fig. 1) can be approximated with a maximum error $\pm 10\%$ by the following criterial dependences:

in the range $Re = 200-600$

$$Nu = 0.71 \left(1 - \frac{12.2}{l/d_{eq} + 16} \right) Re^{0.185 \left(1 + \frac{12.9}{l/d_{eq} + 6} \right)},$$

$$\xi = 11.4 \left(1 + \frac{2.13}{l/d_{eq} + 2} \right) / Re^{0.745},$$

in the range $Re = 600-2500$

$$Nu = 0.016 \left(1 + \frac{7}{l/d_{eq} + 4} \right) Re^{0.77},$$

$$\xi = 9.5 \left(1 - \frac{11.2}{l/d_{eq} + 13} \right) / Re^{0.71 \left(1 - \frac{2.36}{l/d_{eq} + 4} \right)}.$$

The heat-exchange intensity on surfaces of type E (see Fig. 1) grows because of the influence of two factors: boundary layer recovery on the short finned ribs, and stream turbulization during periodic changes in the direction of working medium motion in the channel. In the low Re number range (to 600-1000) elements of type E are capable of assuring an essential increase in the heat-exchange coefficients as compared with a C-1 surface (by 60-80% depending on l/d_{eq} and ψ). The hydraulic losses hence increase to the same extent (see Table 2). In the high Re number range $Re = 2000-4000$, a significantly more intensive growth in the hydraulic losses is observed.

Surfaces of type G with double-deck ribbing (see Fig. 1) turn out to be similar in their thermal and hydraulic characteristics to the characteristics of E-type surfaces with the same values of the parameters l/d_{eq} and ψ (see Table 2).

The surfaces were compared by juxtaposing the size-weight indices of counterflow heat exchangers used as gas-turbine engine regenerators. The juxtaposition was carried out for the same values of the degree of regeneration and pressure loss in the channels (Fig. 4).

Use of surfaces of type D with short ribs instead of the surface C-2 with smooth long channels of the same profile permits an essential improvement in the heat-exchanger index (Fig. 4a): for $l/d_{eq} \approx 4$ the volume and area of the heating surface (or the weight) of the matrix can be reduced by 40-50%, the area of the frontal surface is hence also diminished somewhat. A further shortening of the lengths of individual ribs is hardly expedient since this yields no noticeable advantages in the size or weight of the heat exchanger but complicates the technology of fabricating the elements.

The influence of the quantity l/d_{eq} on type E surfaces with the corrugations inclined relative to the stream was found to be similar to that described above (Fig. 4a).

The use of surfaces of type E in place of C-1 yields the greatest gain in the size-weight indices of the heat exchanger for relatively low numbers $Re < 1000-1500$ (small d_{eq}) (Fig. 4b). Good results can hence be obtained for both the use of short ribs $l/d_{eq} \approx 3$ at low angles of inclination relative to the stream $\psi \approx 0.175$ (the surface E-4) and of longer (and, therefore, more technological) ribs $l/d_{eq} \approx 12$ at high angles $\psi \approx 0.35$ (the surface E-1).

In the zone of higher values of the criterion Re a rapid growth in the hydraulic losses in type E elements, due to breakaway of the stream on the rib edges as the motion direction changes periodically, diminishes somewhat the advantages achieved by intensification of the heat exchange. Surfaces of type D (Fig. 4b) have more favorable characteristics in this range of Re numbers.

Surfaces with double-deck ribbing of type G are somewhat inferior to surfaces E in their indices (Fig. 4b). Nevertheless, their application in a number of cases may prove expedient since such channels permit an increase in the surface area and the through section in one of the heat carriers by retaining a sufficiently small magnitude of the equivalent channel diameter.

NOTATION

d_{eq}	is the equivalent diameter;
F	is the heating surface area equal to the washed wetted surface;
\bar{F}	is the relative heating surface area;
G	is the heat-carrier flow rate;
k	is the heat-transmission coefficient;
K_c	is the coefficient of head loss at the entrance to the channel determined from the data in [1];
L	is the channel length;
l	is the extent of an individual rib;
p	is the pressure;
$S_{air} = V_{air}/L$	is the through section area;
\bar{S}	is the relative area of the heat-exchanger front;
T	is the heat-carrier temperature;
ΔT_{log}	is the logarithmic mean of the temperature head;
V_{air}	is the volume of the matrix occupied by air;
\bar{V}	is the relative heat-exchanger volume;
W	is the heat-carrier velocity;
α	is the heat-exchange coefficient;
ξ	is the hydraulic resistance coefficient;
ψ_r	is the thermal-resistance coefficient of the ribs;
ψ	is the angle between the direction of adjacent corrugations;
σ	is the ratio between the channel through section and the branchpipe cross section;
η_r	is the degree of regeneration;
$\sum \Delta p/p = \Delta p_I/p_I + \Delta p_{II}/p_{II}$	is the total relative pressure loss in the heat-exchanger channels.

Subscripts

air denotes air;
f denotes fluid;
r denotes rib;
1, 2 denote entrance and exit sections;
I, II denote heat carriers.

LITERATURE CITED

1. V. M. Keis and A. L. London, Compact Heat Exchangers [in Russian], Energiya (1967).
2. V. K. Migai, Inzh.-Fiz. Zh., No. 7 (1958).